



22/ William Street NORWOOD SA

Opportunity to inspect unit 3 this weekend. Tenant is allowing access.

5 tenanted flats on 936m² of prime land.

KEEP THESE 5 FLATS AS AN INVESTMENT WITH A GREAT RENT RETURN OR BUILD ON THE LAND YOUR OWN HOME OR SUBDIVIDE THE INTO 2 (STCC) AND BUILD 2 AMAZING HOMES FOR THE PURPOSE OF SELLING OR LIVE IN ONE AND SELL THE OTHER.

GREAT OPPORTUNITY A RARE FIND IN AN AMAZING LOCATION IN WONDERFUL NORWOOD.

In this part of Norwood there are some amazing new homes that are built on generous land holdings such as this and this is the right spot to do it if that is what you require.

Price : \$ 1,440,000
Land Size : 936 sqm
View : <https://www.bruse.com.au/sale/sa/eastern-suburbs/norwood/residential/land/5551946>



Bevan Bruse
08 8431 8181

Unit 5 floor plan (other units of similar layout)

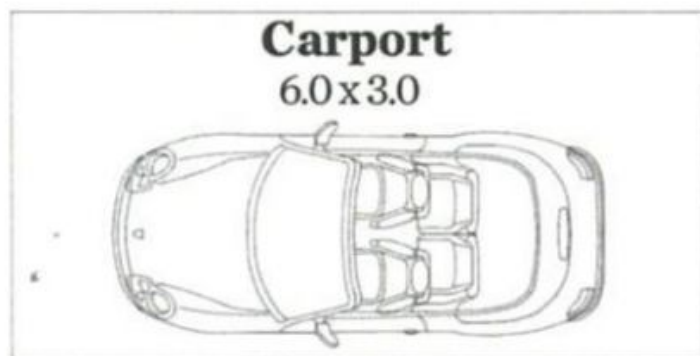

Area (Estimate only)	
Living	45.22 m ²
Carport	18.00 m ²
Total	63.22 m ²